

Recycling Made Simple



Two Stages. One Step.

Washed film. Heavily-printed film.

POLYSTAR MACHINERY
No. 198, Anxin 2nd Rd., Annan Dist.,
Tainan City 709, Taiwan
Tel +886-6-2730889
Fax +886-6-2730887
E-mail sales@polystarco.com
www.polystarco.com

POLYSTAR

Post-consumer

More Flexible for Recyclers

- Handle heavily-printed films and post-consumer waste like a professional.
- Maximize your profits – increasing the return on your investment.



Application

Post-consumer Waste & Heavily-printed Film

Up to
100% Printed Area



Heavily-printed PE/PP film



Multilayered film

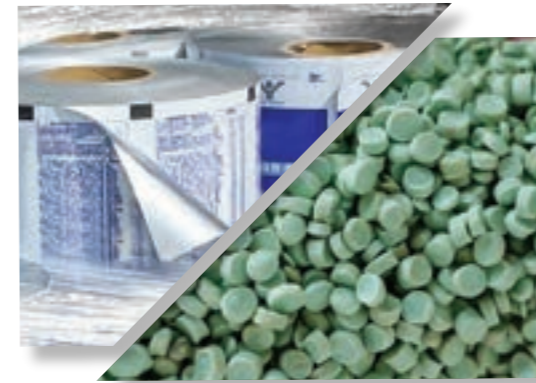

Laminated film-on-rolls

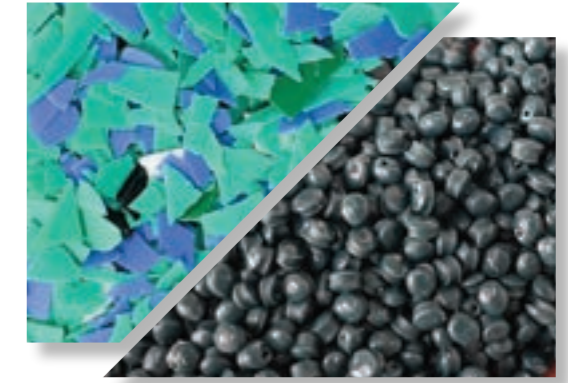

Regrind



Washed and Dried PE/PP film flakes



Soft raffia



Printed woven bags



Non-printed PE/PP film

Adapt with Ease

Simple Design. Maximum Impact.

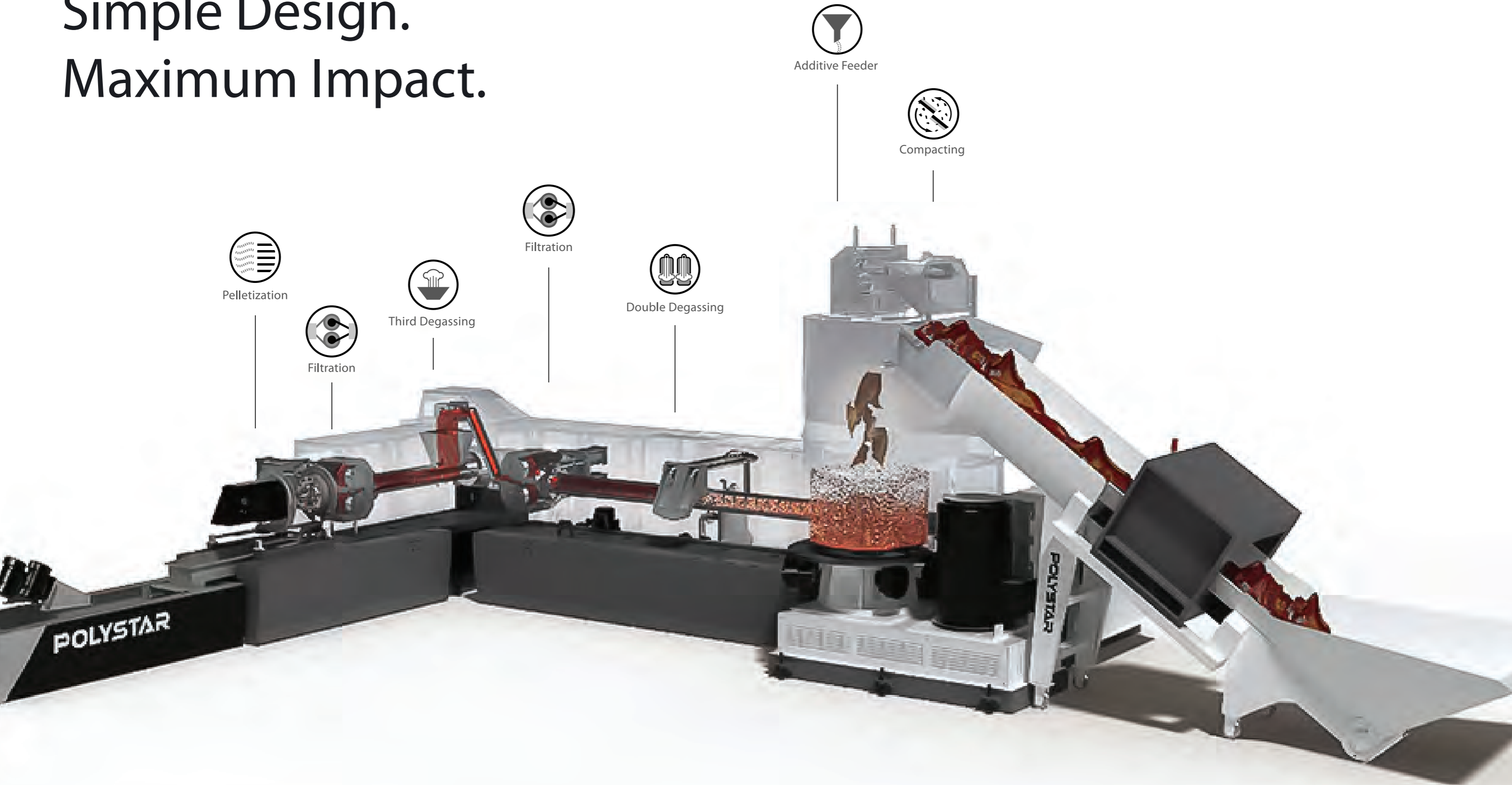

Additive Feeder



Compacting

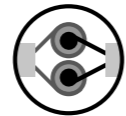

Filtration



Double Degassing



Third Degassing



Filtration



Pelletization

POLYSTAR

POLYSTAR

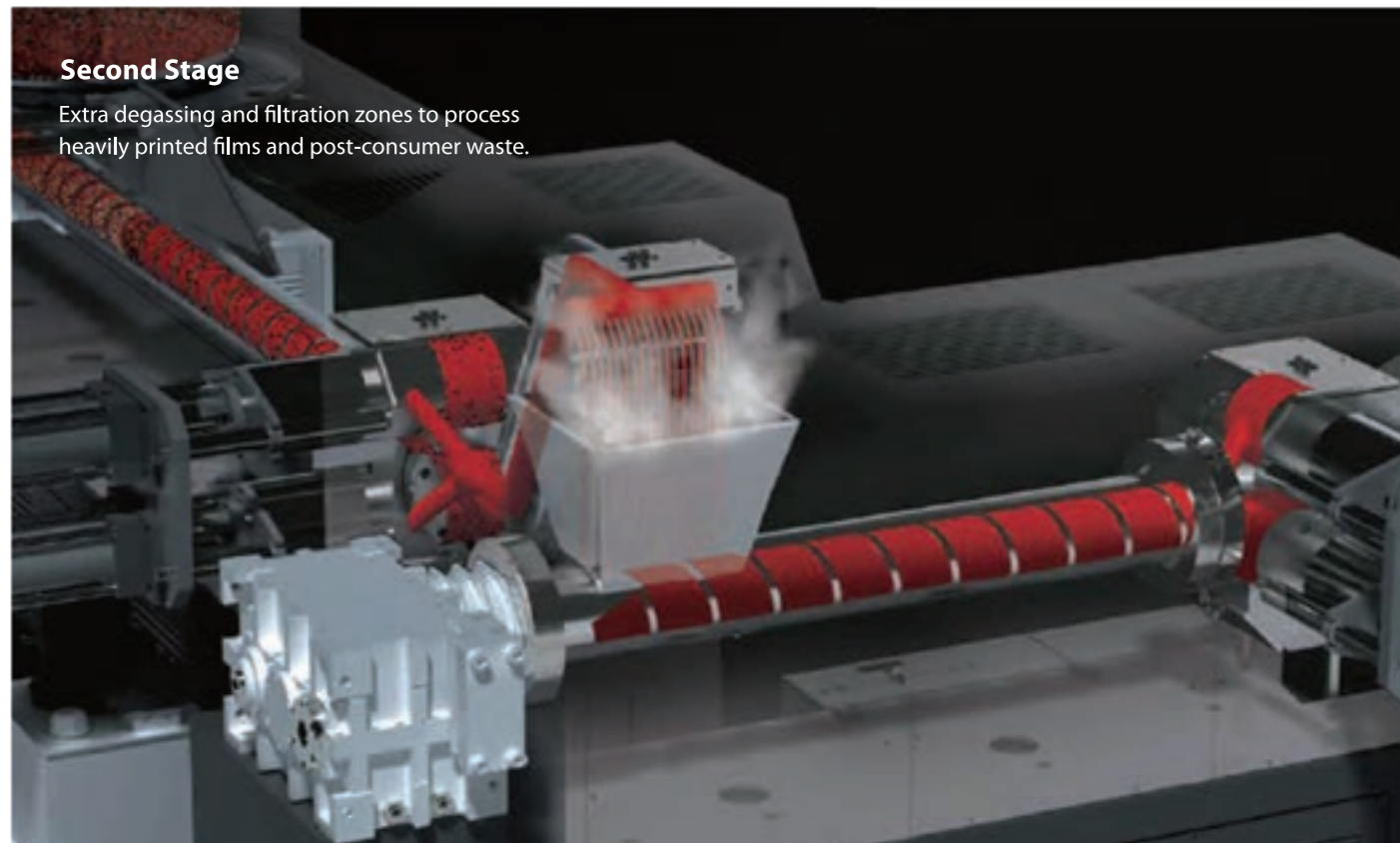
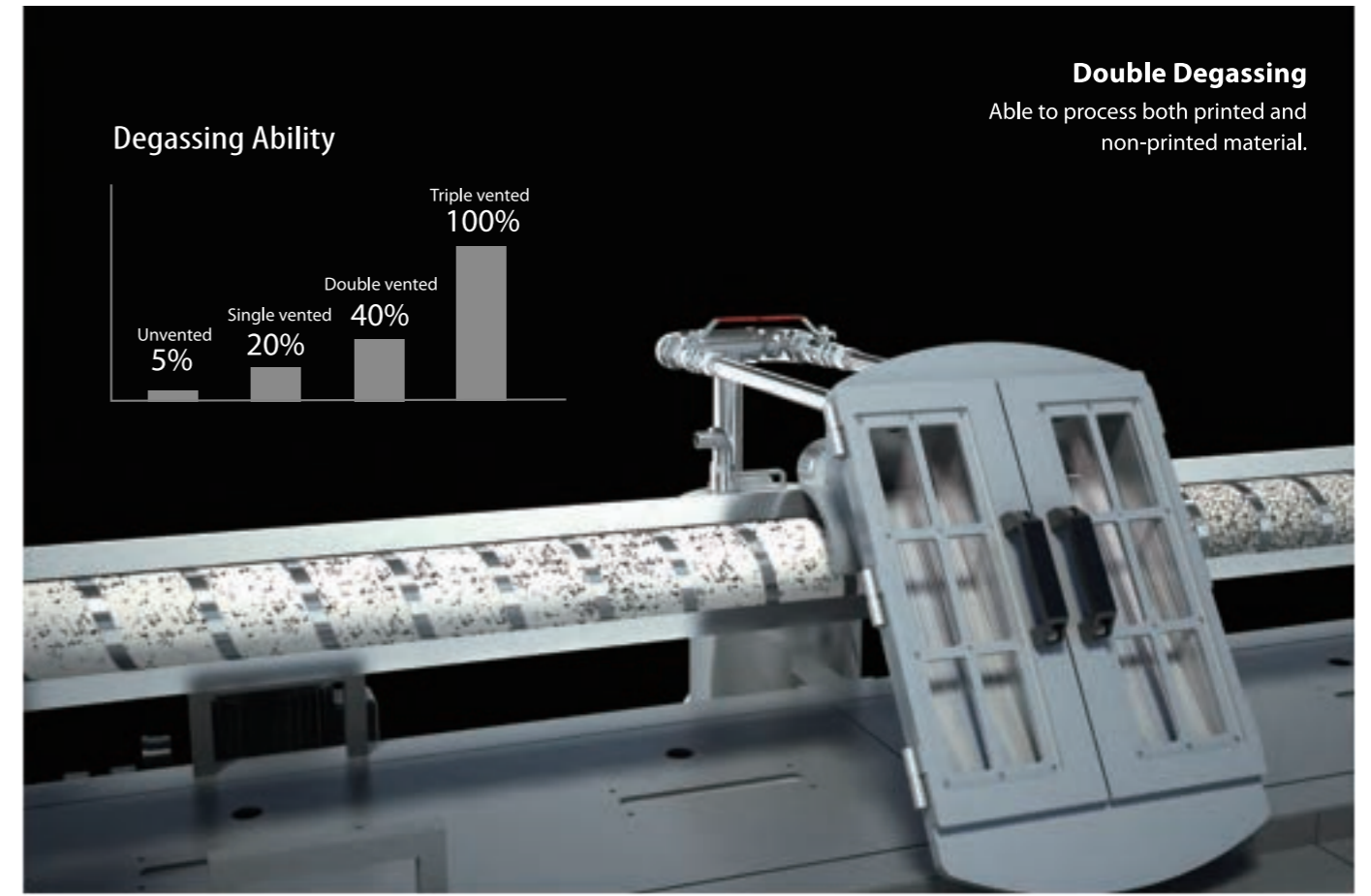
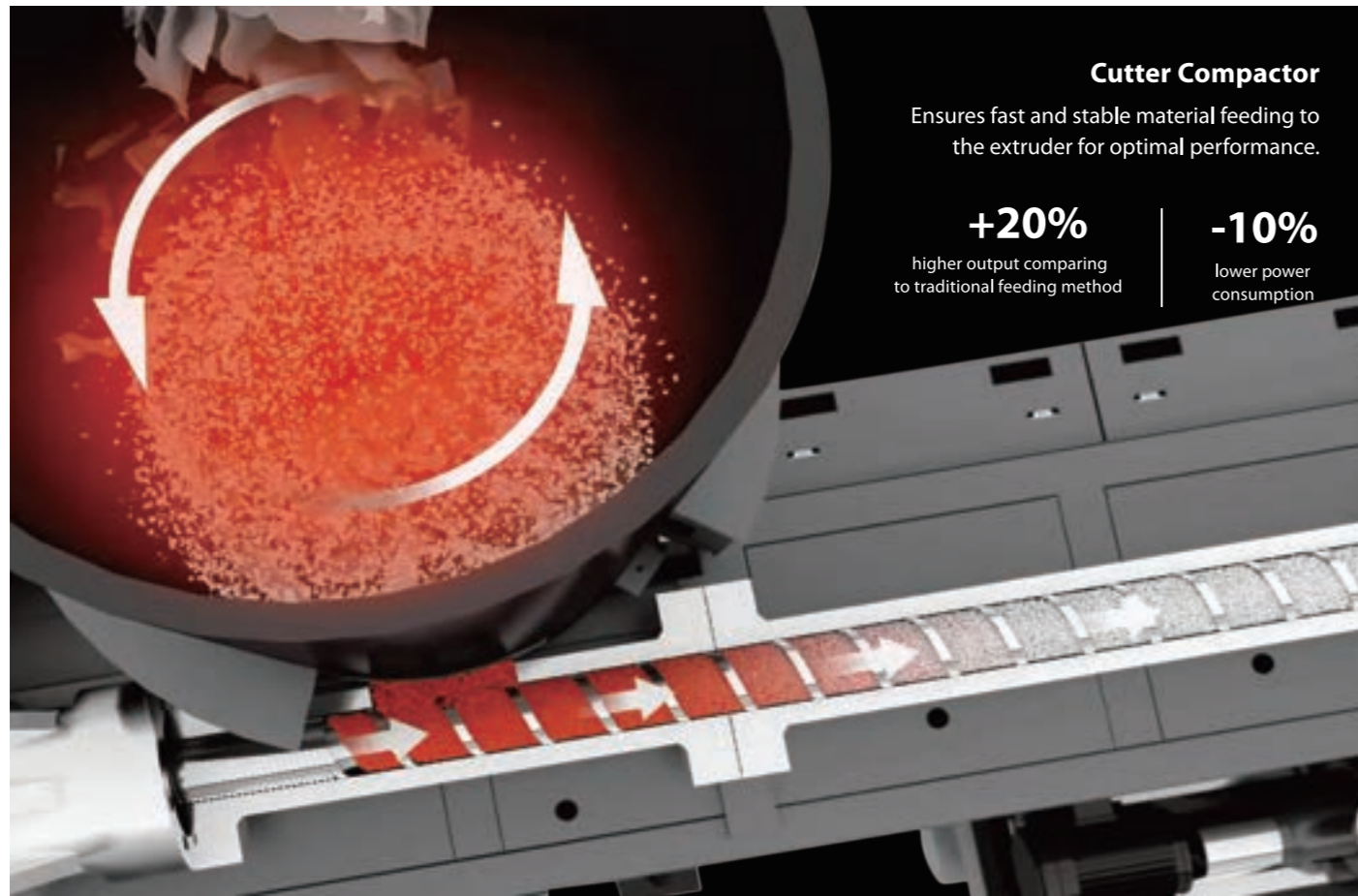



Two Stages. One Step.

Better Degassing. Better Filtration. More Stability.

Model Comparison

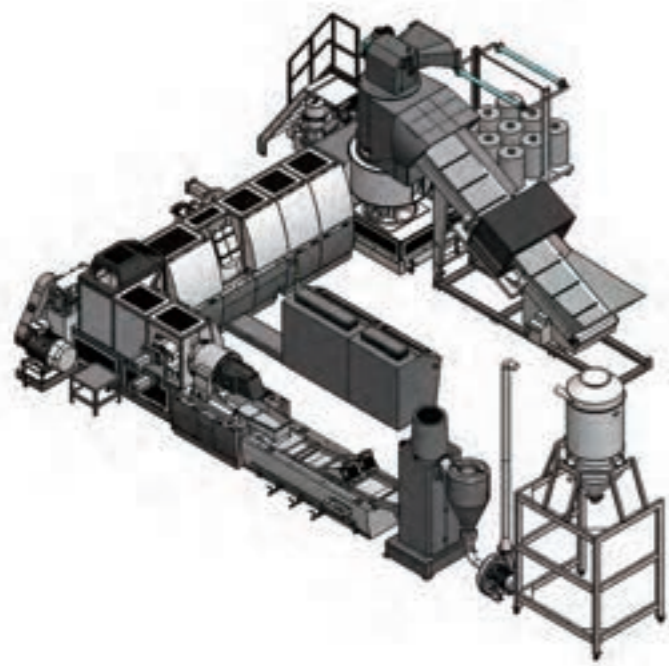

Model	*Output range (kg/hr)
Repro-Flex Plus 65	80~100
Repro-Flex Plus 85	150~250
Repro-Flex Plus 100	300~400
Repro-Flex Plus 120	400~600
Repro-Flex Plus 150	700~800
Repro-Flex Plus 165	850~1000
Repro-Flex Plus 180	900~1100

*Output based on post industrial LDPE film, without degassing.

100%

Customization

- Flexible layout options
- Minimal space requirement
- Personalized design to meet your requirement and factory layout



**World's Simplest
Operation System**



Dosing device

Feed pellet form additives, color masterbatches, and CaCO₃ compounds during the recycling process.



Filter re-positioning

Filtration before degassing ensures excellent-quality pellets from heavily-printed waste.





Different options for screen changers

To reduce machine downtime and frequency of changing the mesh.

4 TYPES of One-step, Integrated Systems For Different Recycling Needs!





Repro-Flex Plastic Recycling Machine

Directly Process	Integration Type	Production	100~1200 kg/hr	Pelletizing Type	Water (die face)
Film (printed & unprinted)	Cutter-Compactor	Filter	Two-channel	Degassing	1 or 2 ventilations
		Material Type	HDPE, LDPE, LLDPE, PP		
		Advantage & Applications	The cutting-compacting process is ideal for light-weight material, especially film waste.		
		Can Also Process	Washed film flakes, film on-roll, pre-crushed raffia / woven, pre-crushed regrind from injection and blow molded.		



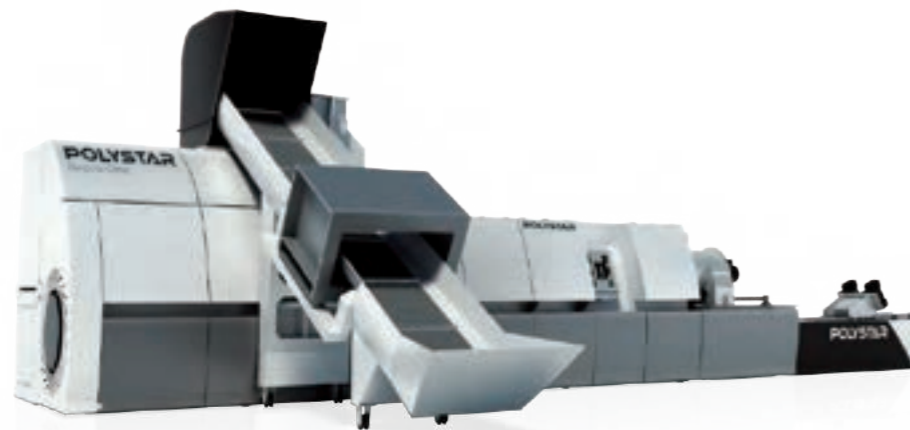

Repro-Direct Hard Plastic Recycling Machine

Directly Process	Integration Type	Production	100~1200 kg/hr	Pelletizing Type	Water (die face)
Rigid Re grind & Hard Plastics	Screw Feeder	Filter	Two-channel	Degassing	1 or 2 ventilations
		Material Type	HDPE, LDPE, LLDPE, PP, PC, PU, BOPP, BOPP+PET, CPP		
		Advantage & Applications	The screw feeding process is ideal for highly abrasive materials in regrind form.		
		Can Also Process	Powder, PS, and ABS.		



Repro-One Shredder Integrated Recycling Machine

Directly Process	Integration Type	Production	100~500 kg/hr	Pelletizing Type	Water (die face)
Raffia & Rigid plastic	Single Shaft Shredder	Filter	Two-channel	Degassing	1 or 2 ventilations
		Material Type	HDPE, LDPE, LLDPE, PP, PC, PU, BOPP, BOPP+PET, CPP		
		Advantage & Applications	Can process rigid material directly with the powerful shredder.		
		Can Also Process	Film on-roll, lumps, Woven/ nonwoven bag.		

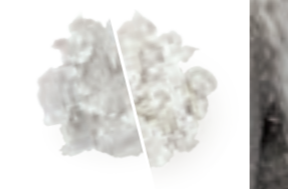
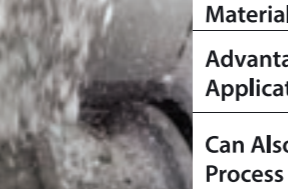

Repro-Dry Pre-washed Film Squeezer Dryer Machine

Directly Process	Integration Type	Production	300 ~ 900 kg/hr	Screw Diameter	Ø 300mm ~ 350mm
Washed Flakes	Hopper Feeding	Final Product	Dried plastic granules	Reduce Water Moisture	1~5%
		Material Type	Dried plastic granules		
		Advantage & Applications	Maximizes output and when working in-line with the combination of the compactor-extruder-pelletizing type of recycling machine.		
		Can Also Process	Post-consumer PE film (pre-washed) LDPE Agricultural film, stretch film PP woven bags, PP jumbo bags		